

DATE OF ISSUE : 2005. 07. 21

SPECIFICATION

MODEL : SLSNNWH804TS

WHITE FLASH LED

CUSTOMER : _____

SAMSUNG ELECTRO-MECHANICS CO, .LTD.

314. MAETAN3-DONG, YEONGTONG-KU,
SUWON-SI, KYUNGKI-DO, KOREA, 442-743

Contents

| | |
|---|-------|
| 1. Product outline----- | 3 |
| 2. Absolute Maximum Rating----- | 3 |
| 3. Characteristics ----- | 3 |
| 4. Chromaticity Diagram ----- | 4 |
| 5. Typical Characteristic Graph ----- | 5 |
| 6. Outline Drawing and Dimension ----- | 6 |
| 7. Package Structure ----- | 6 |
| 8. Reliability Test Items and Conditions -- | 7 |
| 9. Solder Conditions ----- | 8 |
| 10. Taping Dimension ----- | 9 |
| 11. Reel Packing Structure ----- | 10 |
| 12. Label Structure ----- | 11 |
| 13. Precaution for Use ----- | 12 |
| 14. Hazard Substance Analysis----- | 13~14 |
| 15 Revision History ----- | 15 |

■ Product Outline

1) Feature

1. Mini-Mold type (3.0 * 3.0 * t 0.9mm),
2. Beam Angle ($\Delta\theta$: 120 °)
3. GaN/Al₂O₃ Chip & Long Time Reliability

2) Applications

- Mobile Camera Phone, Flashlight for Camera.....

■ Absolute Maximum Rating

- Operation Forward Current Per Chip..... 30 mA
- Peak Pulsed Forward Current Per Chip..... 100 mA
(Duty 1/10 Pulse Width 10msec)
- Reverse Voltage 5V
- Operating Temperature Range (T_{opr}) -35°C ~ 85°C
- Storage Temperature Range (T_{stg}) -40°C ~ 100°C

■ Characteristics

(Ta : 25°C)

| | Rank | Symbol | Min. | Typ. | Max. | Unit | Conditions |
|------------------------|----------|----------------------|------------|------------|------------|-----------|-----------------------------|
| Forward Voltage | S | V_F | 2.9 | 3.4 | 3.8 | V | I_F = 30mA |
| Reverse Current | - | I_r | - | - | 100 | μA | V_r = 5V |

Chromaticity Coordinate

| Rank | x | | | | y | | | | Condition |
|----------|--------------|--------------|--------------|--------------|--------------|--------------|--------------|--------------|-----------------------------|
| E | 0.287 | 0.281 | 0.330 | 0.330 | 0.295 | 0.308 | 0.365 | 0.339 | I_F = 30mA |
| F | 0.287 | 0.296 | 0.330 | 0.330 | 0.295 | 0.276 | 0.318 | 0.339 | |

Luminous Intensity

| Rank | Symbol | Min. | Typ. | Max. | Unit | Conditions |
|----------|-----------|------------|------------|------------|-----------|--|
| S | IV | 1.0 | 1.7 | 2.5 | cd | I_F = 30mA |
| - | IV | - | 3.5 | 5 | cd | I_F=75mA (2sec-On/2sec-OFF) |

- * Tolerance : V_F:±0.1, IV:±10%, x,y:±0.02
- * Luminous intensity measuring equipment : CAS140 B

Chromaticity Diagram

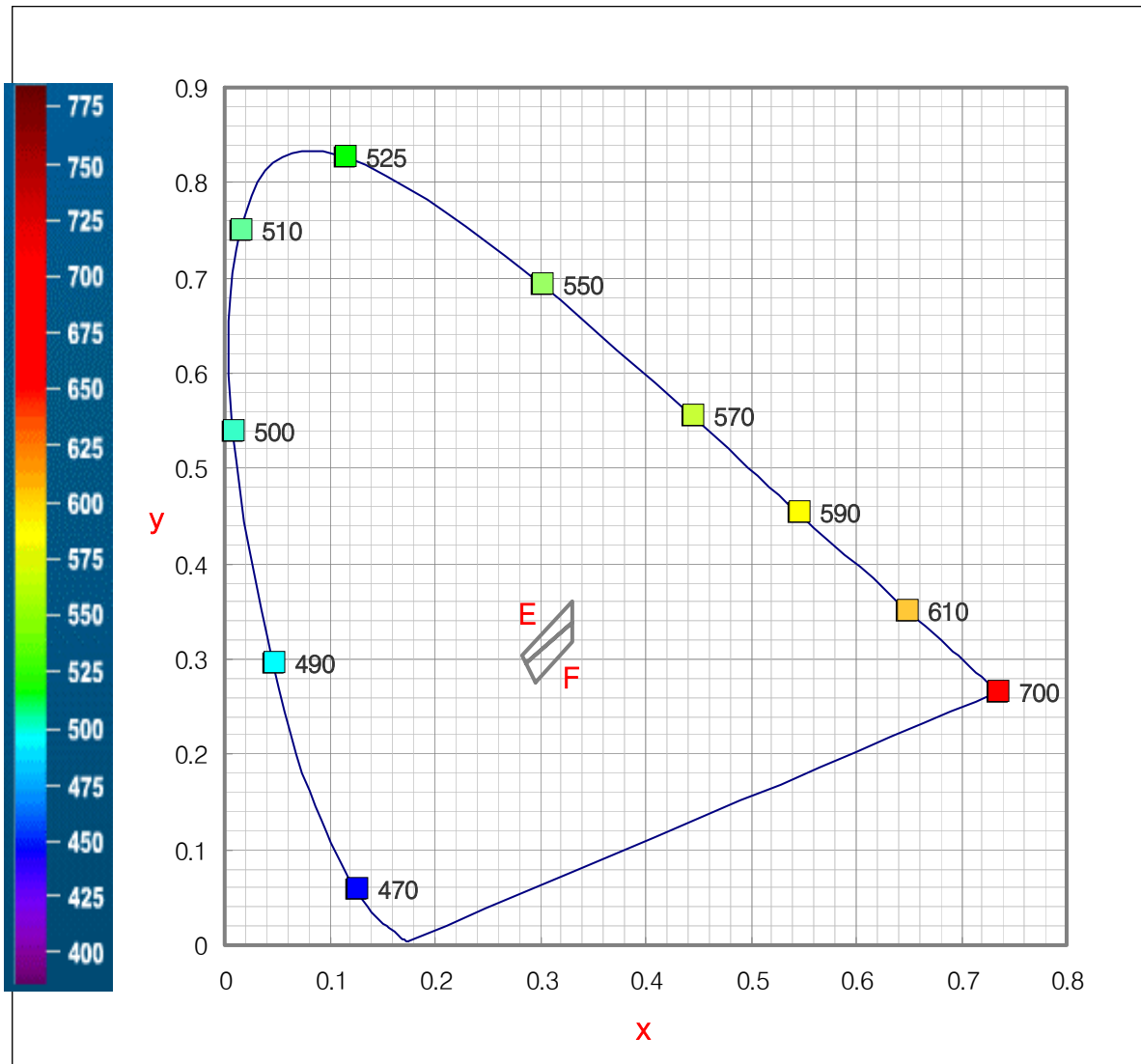

Typical Characteristics Graph

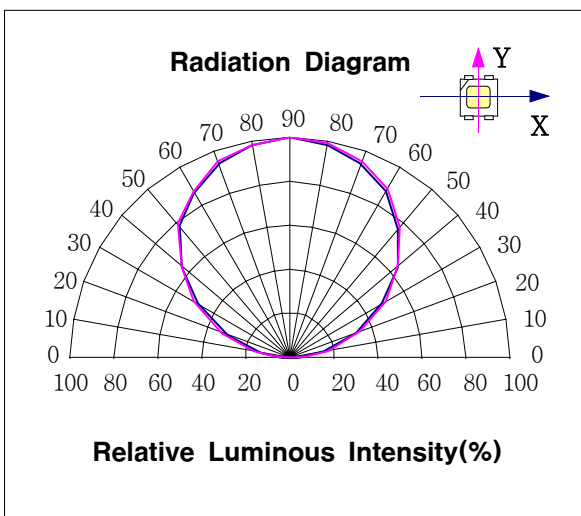
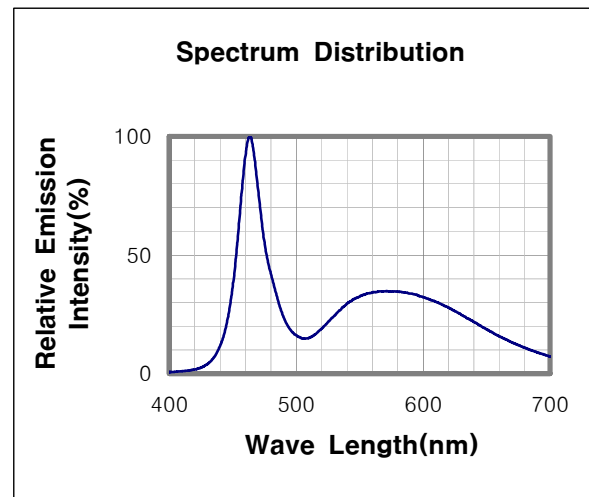
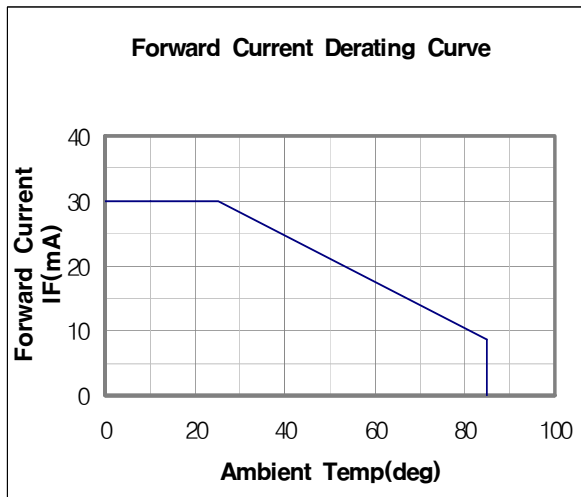
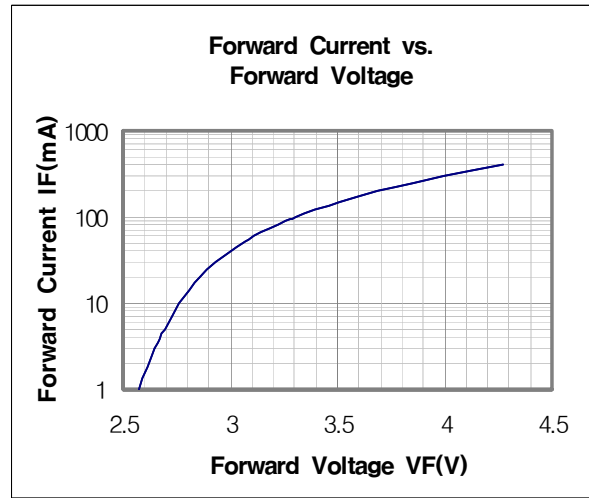
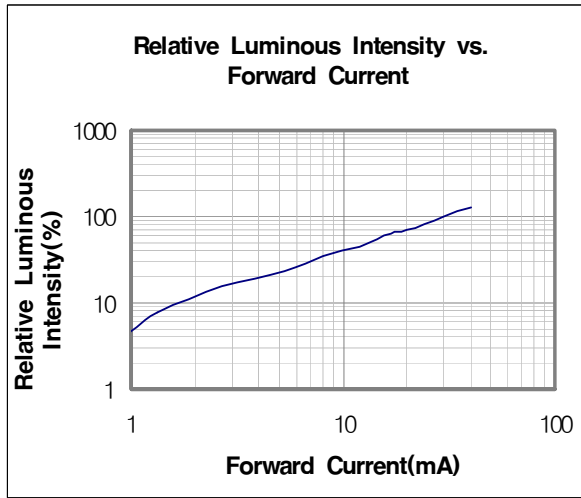

Outline Drawing and Dimension

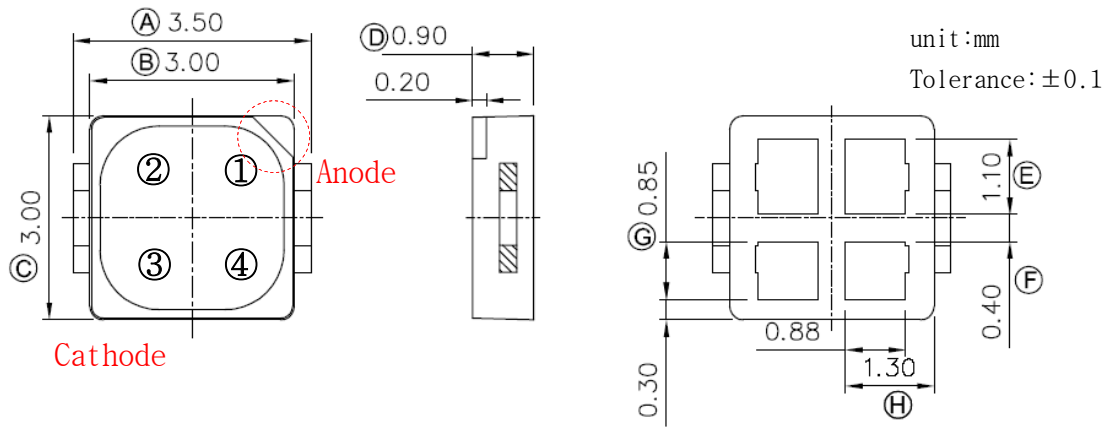

Circuit

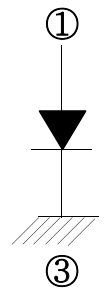

Land Layout

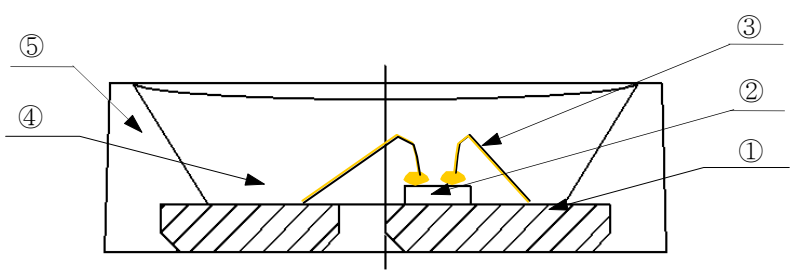
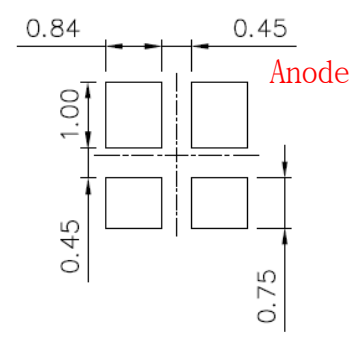

| NUMBER | ITEM | MATERIAL |
|--------|----------|------------------------------------|
| ① | FRAME | Copper Frame(Silver Plated) |
| ② | LED CHIP | GaN/Al ₂ O ₃ |
| ③ | WIRE | Gold Wire |
| ④ | RESIN | Resin + Phosphor |
| ⑤ | PACKAGE | Heat-resistant Polymer |

■ Reliability Test Items and Conditions

1) Test Items and Results

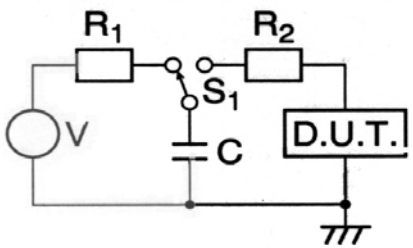
| Test Item | Test Conditions | Test Hours/Cycles | Sample No |
|-------------------------------------|--|-------------------|-----------|
| Room Temperature life test | 25°C±3°C, DC30 mA | 500 h | 0/50 |
| High Temperature humidity life test | 60°C±3°C, 95%±2%RH, DC17 mA | 500 h | 0/50 |
| High Temperature life test | 85°C±3°C, DC8 mA | 500 h | 0/50 |
| Low Temperature life test | -30°C±3°C, DC30 mA | 500 h | 0/50 |
| High Temperature Storage | Ta=100°C±3°C | 500 h | 0/50 |
| Low Temperature Storage | Ta=-40°C±3°C | 500 h | 0/50 |
| High Temperature humidity Storage | 60°C±3°C, 95%±2%RH | 500 h | 0/50 |
| Thermal Shock | -40°C ~ 100°C 0.5 h 0.5 h | 100 cycles | 0/50 |
| Temperature humidity Cycle | 25°C ~ 65°C ~ -10°C 24hrs/1cycle, 95%RH | 10 cycles | 0/22 |
| Reflow (Pb-Free) | Peak 260±5°C for 10sec | 3 times | 0/22 |
| ESD(HBM) |  <p>-R1:10MΩ , R2:1.5KΩ , C:100pF</p> | 5 times | 0/5 |
| On/Off test | 50°C±3°C, 95%±2%RH, DC30 mA, On/2sec, Off/2sec | 108000 cycles | 0/50 |

2) Criteria for Judging the Damage

| Item | Symbol | Test Condition | Limit | |
|--------------------|--------|---------------------|------------|------------|
| | | | Min | Max |
| Forward Voltage | V_F | $I_F = 30\text{mA}$ | - | U.S.L.*1.2 |
| Luminous Intensity | IV | $I_F = 30\text{mA}$ | L.S.L.*0.5 | - |
| Reverse Current | I_R | $V_R=5\text{V}$ | - | U.S.L.*2.0 |

* USL : Upper Standard Level LSL : Lower Standard Level

■ Solder Conditions

1) Reflow Conditions (Pb Free)

Reflow Frequency : 2 times max.

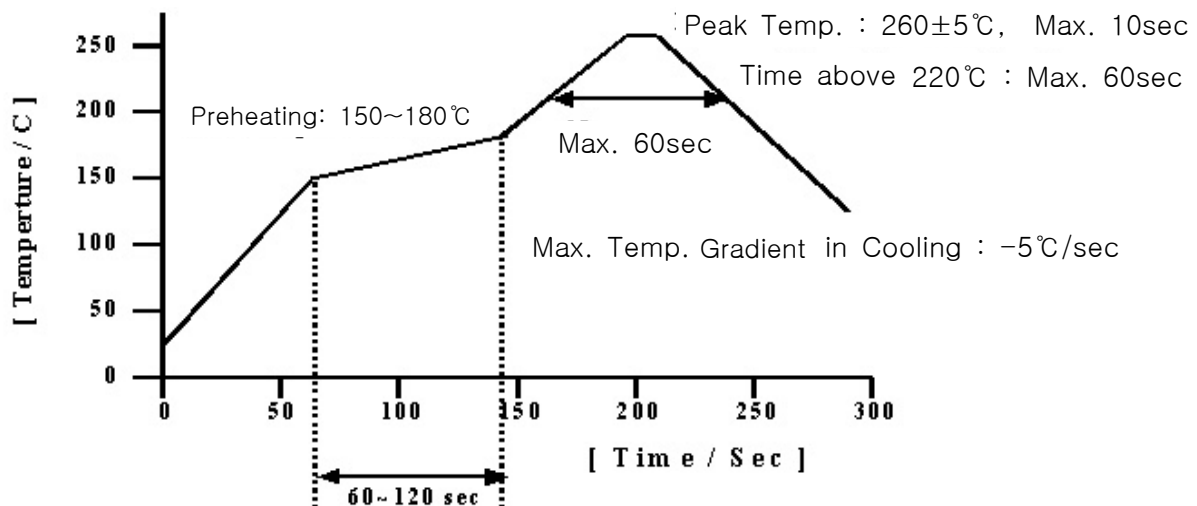

2) For Manual Soldering

Not more than 5 seconds @MAX 300°C , under soldering iron.

■ Taping Dimension

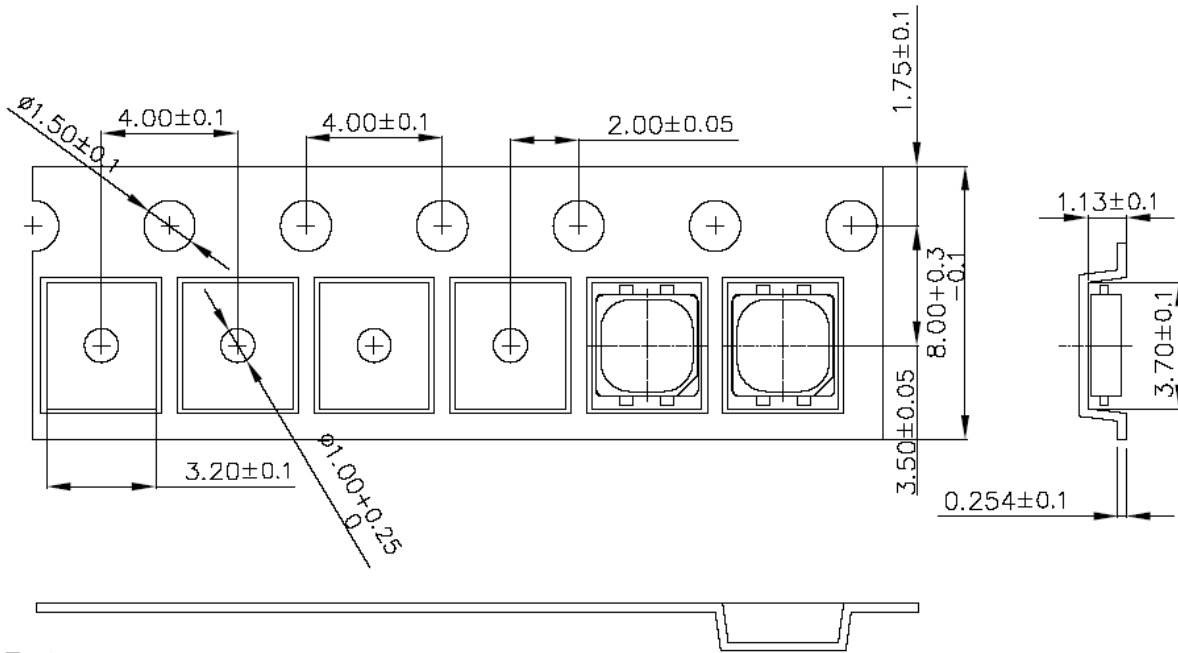

End

Start

More than 40mm
Unloaded tape

Mounted with
Chip LED

More than 100~200mm
Unloaded tape

Leading part more than
200~400mm

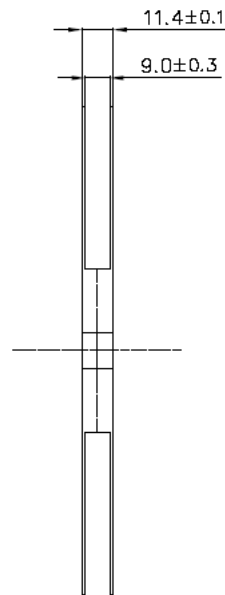
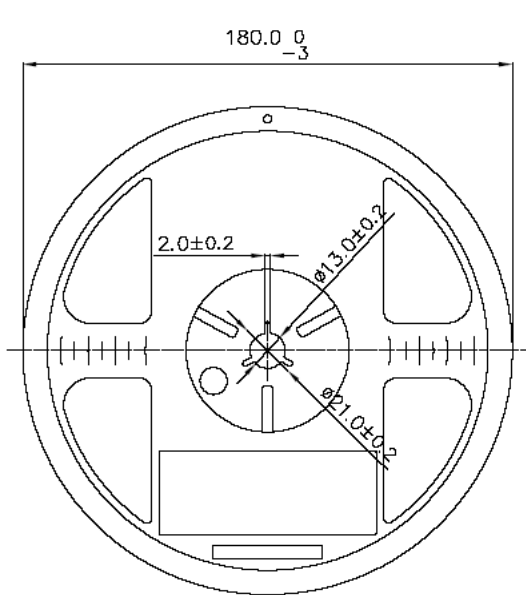

Tolerance : ± 0.2 , Unit:mm

- (1) Quantity : The quantity/Reel to be 3000pcs.
- (2) Cumulative Tolerance : Cumulative tolerance/10 pitches to be ± 0.2 mm
- (3) Adhesion Strength of Cover Tape : Adhesion strength to be 0.1~0.7N when the cover tape is turned off from the carrier tape at 10° angle to be the carrier tape.
- (4) Packaging : P/N, Manufacturing data code no. and quantity to be indicated on a damp proof Package.

■ Label Structure

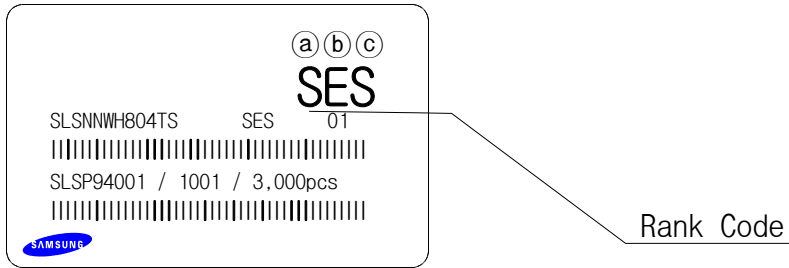

- Ⓐ : VF Rank
- Ⓑ : Chromaticity Coordinate Rank
- Ⓒ : IV Rank

■ Precaution for use

1. This device should not be used in any type of fluid such as water, oil, organic solvent, etc.
When washing is required, IPA should be used.
2. When the LEDs are illuminating, operating current should be decided after considering the ambient maximum temperature.
3. LEDs must be stored to maintain a clean atmosphere.
If the LEDs are stored for 3 months or more after being shipped from Samsung Electro-Mechanics, a sealed container with a nitrogen atmosphere should be used for storage.
4. The LEDs must be used within seven days after opening the moisture proof packing. Repack unused Products with anti-moisture packing, fold to close any opening and then store in a dry place.
5. The appearance and specifications of the product may be modified for improvement without notice.
6. This LEDs is sensitive to the static electricity and surge. It is recommended to use a wrist band or anti-electrostatic glove when handling the LEDs.

If over voltage which exceeds the absolute maximum rating is applied to LEDs, it will cause damage LEDs and result in destruction.

Damaged LEDs will show some unusual characteristics such as leak current remarkably increase, turn-on voltage becomes lower and the LEDs get unlighted at low current.

