

## Multilayer Ceramic Chip Capacitors



### Introduction

Multilayer Surface Mount Ceramic Capacitors are constructed by screen printing alternative layers of internal metallic electrodes onto ceramic dielectric materials and firing into a concrete monolithic body, then completed by application of metal end terminations which are fired to assure permanent bonding with the individual internal electrodes.

Multilayer ceramic capacitors have various features such as large capacitance values in small sizes and excellent high frequency characteristics.

Moreover, chip capacitors can be used on surface mount assembly equipment. Our fully integrated manufacturing and total quality control systems ensure unprecedented high standards of quality and reliability.

---

### Chip Capacitor Selection

Selection of the most suitable capacitor for any application is based on the following:

#### **Dielectric Type**

The choice of dielectric is largely determined by the temperature stability required.

#### **COG (NPO)**

Capacitance change with temperature is 0-30ppm/°C which is less than -0.3%/°C from -55°C to +125°C. Typical capacitance change with life is less than -0.1% for NPOs, one-fifth that shown by most other dielectrics. NPO formulations show no aging characteristics.

#### **X7R/X5R**

Its temperature variation of capacitance is within ±15% from -55°C to +125°C (-55°C to +85°C for X5R). The capacitance change is non-linear.

#### **Z5U**

Despite their capacitance instability, Z5U formulations are very popular because of their small size, temperature range low ESL, low ESR and excellent frequency response. These features are particularly important for decoupling application where only a minimum capacitance value is required.

#### **Y5V**

Y5V formulations are for general purpose use in a limited temperature range. They have a wide temperature characteristic of +22% - 82% capacitance change over the operating temperature range of -30°C to +85°C. Y5Vs high dielectric constant allows the manufacture of very high capacitance values (up to 22MF) in small physical sizes.

#### **Capacitance Value & Tolerance**

Determined by circuit requirements. Note that chip prices decrease with lower capacitance value and looser tolerance.

#### **Voltage**

Determined by circuit requirements. Units are designed to exceed the withstanding voltage specification, i.e., the user need not incorporate an additional safety margin.

#### **Capacitor Size**

Select the smallest unit permitted by the circuit constraints that provides the required capacitance and voltage rating. All Cal-Chip capacitors conform to EIA specifications.

#### **Capacitor Termination**

Nickel barrier is standard and recommended for units exposed to repeated solder cycles, to minimize leaching of the termination.

## Multilayer Ceramic Chip Capacitors



### Construction

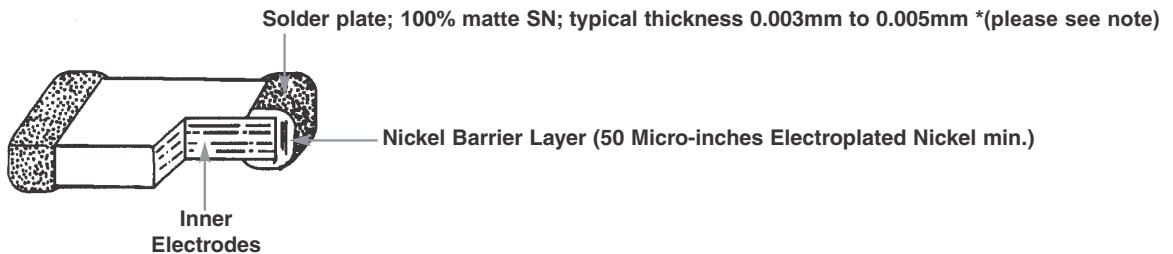

### Example

<b>GMC21</b>	<b>CG</b>	<b>102</b>	<b>J</b>	<b>50</b>	<b>N</b>	<b>T</b>																		
Size Code	Dielectric	Capacitance (pF)	Capacitance Tolerance (EIA Code)	Voltage	Termination	Packaging Code																		
	CG (COG) (NPO) X7R or X5R Z5U Y5V		B ±0.1pf for ≤ 10pF C ±0.25pF for ≤ 10pF D ±0.5pF for ≤ 10pF F ±1% G ±2% J ±5% K ±10% M ±20% Z -20%~+80%		6r3 6.3 DC 10 10 DC 16 16 DC 25 25 DC 50 50 DC 100 100 DC 200 200 DC	N Nickel Barrier T Tape and Reel																		
<p>Capacitance values are represented in 3 digits, and expressed in pF. The first two digits are significant, and the third is the number of zeros. The letter "R" is used as a decimal point.</p> <table border="1"> <tr><td>0R5</td><td>0.5pF</td></tr> <tr><td>5R0</td><td>5pF</td></tr> <tr><td>100</td><td>10pF</td></tr> <tr><td>101</td><td>100pF</td></tr> <tr><td>102</td><td>1000pF</td></tr> <tr><td>103</td><td>.01mF</td></tr> <tr><td>104</td><td>.1mF</td></tr> <tr><td>105</td><td>1.0mF</td></tr> <tr><td>106</td><td>10mF</td></tr> </table>		0R5	0.5pF	5R0	5pF	100	10pF	101	100pF	102	1000pF	103	.01mF	104	.1mF	105	1.0mF	106	10mF					
0R5	0.5pF																							
5R0	5pF																							
100	10pF																							
101	100pF																							
102	1000pF																							
103	.01mF																							
104	.1mF																							
105	1.0mF																							
106	10mF																							

\*Note: Calchip has completed the Lead-Free transition. All parts shipped with or without the "custom designator" LF at the end of the part number will be Lead-Free. Lead-Free material will still continue to have an LF at the end of the Lot Code and a green RoHS symbol on the label. Please contact your sales associate if you require non-RoHS material.



## Multilayer Ceramic Chip Capacitors

**0201**

**GMC02**

DIMENSION (MM)

<b>L</b>	<b>0.6 ± 0.03</b>						
<b>W</b>	<b>0.3 ± 0.03</b>						
<b>H</b>	<b>0.3 ± 0.03</b>						
<b>BW</b>	<b>0.15 ± 0.05</b>						
dielectric	<b>NPO/COG</b>	<b>X5R</b>		<b>X7R</b>			<b>Y5V/Z5U</b>
Rated Voltage	<b>25</b>	<b>6.3</b>	<b>10</b>	<b>6.3</b>	<b>10</b>	<b>16</b>	<b>6.3</b>
Cap. Range							
0.5pF 0R5							
1.0 1R0							
1.2 1R2							
1.5 1R5							
1.8 1R8							
2.2 2R2							
2.7 2R7							
3.3 3R3							
3.9 3R9							
4.7 4R7							
5.6 5R6							
6.8 6R8							
8.2 8R2							
10 100							
12 120							
15 150							
18 180							
22 220							
27 270							
33 330							
39 390							
47 470							
56 560							
68 680							
82 820							
100 101							
120 121							
150 151							
180 181							
220 221							
270 271							
330 331							
390 391							
470 471							
560 561							
680 681							
820 821							
1.0nF 102							
1.2 122							
1.5 152							
1.8 182							
2.2 222							
2.7 272							
3.3 332							
3.9 392							
4.7 472							
5.6 562							
6.8 682							
8.2 822							
10 103							
12 123							
15 153							
18 183							
22 223							
27 273							
33 333							
39 393							
47 473							
56 563							
68 683							
82 823							
100 104							
120 124							
150 154							
180 184							
220 224							
270 274							
330 334							
390 394							
470 474							
560 564							
680 684							
820 824							
1.0uF 105							
2.2 225							



## Multilayer Ceramic Chip Capacitors 0402 & 0603

### GMC04

### GMC10

Type	0402														0603																		
Length (L1)	mm							inches							mm							inches											
	1.0±0.05							0.04±0.002							1.6±0.2							0.063±0.008											
Width (W)	mm							inches							mm							inches											
	0.5±0.05							0.02±0.002							0.8±0.2							0.031±0.008											
Thickness (H)	mm							inches							mm							inches											
	0.5±0.1							0.02±0.004							0.8±0.2							0.031±0.008											
Termination Band (L2+L3)	mm							inches							mm							inches											
	Min 0.1 0.004							Max 0.35 0.014							Min 0.1 0.004							Max 0.4 0.015											
Band Gap (L4)	mm							inches							mm							inches											
	0.3 0.012							0.6 0.015							0.3 0.012							0.6 0.015											
Dielectric	COG		X5R		X7R		Y5V & Z5U		COG		X5R		X7R		Y5V & Z5U																		
Rated Voltage d.c.	25	50	6.3	10	16	6.3	10	16	25	50	6.3	10	16	25	50	25	50	100	6.3	10	16	6.3	10	16	25	50/100	6.3	10	16	25	50		
Cap Range	Code																																
0.5pF	0R5																																
1.0	1R0																																
1.2	1R2																																
1.5	1R5																																
1.8	1R8																																
2.2	2R2																																
2.7	2R7																																
3.3	3R3																																
3.9	3R9																																
4.7	4R7																																
5.6	5R6																																
6.8	6R8																																
8.2	8R2																																
10	100																																
12	120																																
15	150																																
18	180																																
22	220																																
27	270																																
33	330																																
39	390																																
47	470																																
56	560																																
68	680																																
82	820																																
100	101																																
120	121																																
150	151																																
180	181																																
220	221																																
270	271																																
330	331																																
390	391																																
470	471																																
560	561																																
680	681																																
820	821																																
1.0nF	102																																
1.2	122																																
1.5	152																																
1.8	182																																
2.2	222																																
2.7	272																																
3.3	332																																
3.9	392																																
4.7	472																																
5.6	562																																
6.8	682																																
8.2	822																																
10	103																																
12	123																																
15	153																																
18	183																																
22	223																																
27	273																																
33	333																																
39	393																																
47	473																																
56	563																																
68	683																																
82	823																																
100	104																																
150	154																																
220	224																																
270	274																																
330	334																																
390	394																																
470	474																																
560	564																																
680	684																																
820	824																																
1.0uF	105																																
2.2	225																																
2.7	275																																
3.3	335																																
3.9	395																																
4.7	475																																
5.6	565																																
6.8	685																																
8.2	825																																
10	106																																
15	156																																
22	226																																
33	336																																
47	476																																



## Multilayer Ceramic Chip Capacitors COG/NPO

		GMC21		GMC31		GMC32		GMC40		GMC43		GMC45		GMC55		GMC57	
Type		0805		1206		1210		1808		1812		1825		2220		2225	
Length	mm	2.0±0.3		3.2±0.3		3.2±0.3		4.57±0.25		4.5±0.35		4.5±0.35		5.7±0.4		5.7±0.4	
	Inches	0.08±0.012		0.125±0.012		0.125±0.012		0.18±0.01		0.18±0.014		0.18±0.014		0.225±0.016		0.225±0.016	
Width	mm	1.25±0.2		1.6±0.2		2.5±0.3		2.03±0.25		3.2±0.3		6.3±0.4		5.0±0.4		6.3±0.4	
	Inches	0.05±0.008		0.063±0.008		0.10±0.012		0.08±0.01		0.125±0.012		0.25±0.016		0.197±0.016		0.25±0.016	
Thick(Max)	mm	1.3		1.6		1.8		2.03		1.8		1.8		1.8		1.8	
	Inches	0.051		0.063		0.07		0.08		0.07		0.07		0.07		0.07	
Termination Band	mm	Min	Max	Min	Max	Min	Max	Min	Max	Min	Max	Min	Max	Min	Max	Min	Max
	Inches	0.25	0.75	0.25	0.75	0.25	0.75	0.25	0.75	0.25	0.75	0.25	0.75	0.25	0.75	0.25	0.75
		0.01	0.03	0.01	0.03	0.01	0.03	0.01	0.03	0.01	0.03	0.01	0.03	0.01	0.03	0.01	0.03
Band Gap	mm	0.5		1.4		1.4		2.0		2.2		2.2		2.9		2.9	
	Inches	0.019		0.055		0.055		0.078		0.087		0.087		0.114		0.114	
Rated Voltage d.c.		16	25	50	25	50	16	25	50/63	50/63	50/63	50/63	50/63	50/63	50/63	50/63	50/63
Cap. Range	Code																
0.5pF	0R5																
1.0	1R0																
1.2	1R2																
1.5	1R5																
1.8	1R8																
2.2	2R2																
2.7	2R7																
3.3	3R3																
3.9	3R9																
4.7	4R7																
5.6	5R6																
6.8	6R8																
8.0	8R0																
10	100																
12	120																
15	150																
18	180																
22	220																
27	270																
33	330																
39	390																
47	470																
56	560																
68	680																
82	820																
100	101																
120	121																
150	151																
180	181																
220	221																
270	271																
330	331																
390	391																
470	471																
560	561																
680	681																
820	821																
1.0nF	102																
1.2	122																
1.5	152																
1.8	182																
2.2	222																
2.7	272																
3.3	332																
3.9	392																
4.7	472																
5.6	562																
6.8	682																
8.2	822																
10	103																
12	123																
15	153																
18	183																
22	223																
27	273																
33	333																
39	393																
47	473																
56	563																
68	683																
82	823																
100	104																
120	124																
150	154																
180	184																
220	224																
270	274																
330	334																
390	394																
470	474																
560	564																
680	684																
820	824																
1.0uF	105																
2.2	225																
3.3	335																
4.7	475																
6.8	685																
10	106																
22	226																
33	336																
47	476																
100	107																



## Multilayer Ceramic Chip Capacitors

COG/NPO (cont.)

		GMC21		GMC31		GMC32		GMC40		GMC43		GMC45		GMC55		GMC57	
Type		0805		1206		1210		1808		1812		1825		2220		2225	
Length	mm	2.0±0.3		3.2±0.3		3.2±0.3		4.57±0.25		4.5±0.35		4.5±0.35		5.7±0.4		5.7±0.4	
	Inches	0.08±0.012		0.125±0.012		0.125±0.012		0.18±0.01		0.18±0.014		0.18±0.014		0.225±0.016		0.225±0.016	
Width	mm	1.25±0.2		1.6±0.2		2.5±0.3		2.03±0.25		3.2±0.3		6.3±0.4		5.0±0.4		6.3±0.4	
	Inches	0.05±0.008		0.063±0.008		0.10±0.012		0.08±0.01		0.125±0.012		0.25±0.016		0.197±0.016		0.25±0.016	
Thick(Max)	mm	1.3		1.6		1.8		2.03		1.8		1.8		1.8		1.8	
	Inches	0.051		0.063		0.07		0.08		0.07		0.07		0.07		0.07	
Termination Band	mm	Min	Max	Min	Max	Min	Max	Min	Max	Min	Max	Min	Max	Min	Max	Min	Max
	Inches	0.25	0.75	0.25	0.75	0.25	0.75	0.25	0.75	0.25	0.75	0.25	0.75	0.25	0.75	0.25	0.75
Band Gap	mm	0.5		1.4		1.4		2.0		2.2		2.2		2.9		2.9	
	Inches	0.019		0.055		0.055		0.078		0.087		0.087		0.114		0.114	
Rated Voltage d.c.		100	200	100	200	100	200	100	200	100	200	100	200	100	200	100	200
Cap. Range	Code																
0.5pF	0R5																
1.0	1R0																
1.2	1R2																
1.5	1R5																
1.8	1R8																
2.2	2R2																
2.7	2R7																
3.3	3R3																
3.9	3R9																
4.7	4R7																
5.6	5R6																
6.8	6R8																
8.2	8R2																
10	100																
12	120																
15	150																
18	180																
22	220																
27	270																
33	330																
39	390																
47	470																
56	560																
68	680																
82	820																
100	101																
120	121																
150	151																
180	181																
220	221																
270	271																
330	331																
390	391																
470	471																
560	561																
680	681																
820	821																
1.0nF	102																
1.2	122																
1.5	152																
1.8	182																
2.2	222																
2.7	272																
3.3	332																
3.9	392																
4.7	472																
5.6	562																
6.8	682																
8.2	822																
10	103																
12	123																
15	153																
18	183																
22	223																
27	273																
33	333																
39	393																
47	473																
56	563																
68	683																
82	823																
100	104																
120	124																
150	154																
180	184																
220	224																
270	274																
330	334																
390	394																
470	474																
560	564																
680	684																
820	824																
1.0uF	105																
2.2	225																
3.3	335																
4.7	475																
6.8	685																
10	106																
22	226																
33	336																
47	476																
68	686																
100	107																



## Multilayer Ceramic Chip Capacitors X7R

	GMC21			GMC31			GMC32			GMC40			GMC43			GMC45			GMC55			GMC57		
Type	0805			1206			1210			1808			1812			1825			2220			2225		
Length	mm			mm			mm			mm			mm			mm			mm			mm		
	Inches			Inches			Inches			Inches			Inches			Inches			Inches			Inches		
Width	mm			mm			mm			mm			mm			mm			mm			mm		
	Inches			Inches			Inches			Inches			Inches			Inches			Inches			Inches		
Thick(Max)	mm			mm			mm			mm			mm			mm			mm			mm		
	Inches			Inches			Inches			Inches			Inches			Inches			Inches			Inches		
Termination Band	Min	Max		Min	Max		Min	Max		Min	Max		Min	Max		Min	Max		Min	Max		Min	Max	
	mm			mm			mm			mm			mm			mm			mm			mm		
	Inches			Inches			Inches			Inches			Inches			Inches			Inches			Inches		
Band Gap	mm			mm			mm			mm			mm			mm			mm			mm		
	Inches			Inches			Inches			Inches			Inches			Inches			Inches			Inches		
Rated Voltage d.c.	6.3	10	16	25	6.3	10	16	25	10	16	25	10	16	25	10	16	25	10	16	25	10	16	25	
Cap. Range	Code																							
0.5pF	0R5																							
1.0	1R0																							
1.2	1R2																							
1.5	1R5																							
1.8	1R8																							
2.2	2R2																							
2.7	2R7																							
3.3	3R3																							
3.9	3R9																							
4.7	4R7																							
5.6	5R6																							
6.8	6R8																							
8.2	8R2																							
10	100																							
12	120																							
15	150																							
18	180																							
22	220																							
27	270																							
33	330																							
39	390																							
47	470																							
56	560																							
68	680																							
82	820																							
100	101																							
120	121																							
150	151																							
180	181																							
220	221																							
270	271																							
330	331																							
390	391																							
470	471																							
560	561																							
680	681																							
820	821																							
1.0nF	102																							
1.2	122																							
1.5	152																							
1.8	182																							
2.2	222																							
2.7	272																							
3.3	332																							
3.9	392																							
4.7	472																							
5.6	562																							
6.8	682																							
8.2	822																							
10	103																							
12	123																							
15	153																							
18	183																							
22	223																							
27	273																							
33	333																							
39	393																							
47	473																							
56	563																							
68	683																							
82	823																							
100	104																							
120	124																							
150	154																							
180	184																							
220	224																							
270	274																							
330	334																							
390	394																							
470	474																							
560	564																							
680	684																							
820	824																							
1.0uF	105																							
2.2	225																							
3.3	335																							
4.7	475																							
6.8	685																							
10	106																							
22	226																							
33	336																							
47	476																							
68	686																							
100	107																							



## Multilayer Ceramic Chip Capacitors

### X7R (cont)

	GMC21			GMC31			GMC32			GMC40			GMC43			GMC45			GMC55			GMC57				
Type	0805			1206			1210			1808			1812			1825			2220			2225				
Length	mm			3.2±0.3			3.2±0.3			4.57±0.25			4.5±0.35			4.5±0.35			5.7±0.4			5.7±0.4				
	Inches			0.125±0.012			0.125±0.012			0.18±0.01			0.18±0.014			0.18±0.014			0.225±0.016			0.225±0.016				
Width	mm			1.6±0.2			2.5±0.3			2.03±0.25			3.2±0.3			6.3±0.4			5.0±0.4			6.3±0.4				
	Inches			0.063±0.008			0.10±0.012			0.08±0.01			0.125±0.012			0.25±0.016			0.197±0.016			0.25±0.016				
Thick(Max)	mm			1.8			2.8			3.0			3.0			3.2			3.5			3.5				
	Inches			0.063			0.07			0.08			0.07			0.07			0.07			0.07				
Termination Band	Min		Max		Min		Max		Min		Max		Min		Max		Min		Max		Min		Max			
	mm		0.25		0.75		0.25		0.75		0.25		0.75		0.25		0.75		0.25		0.75		0.25		0.75	
	Inches		0.01		0.03		0.01		0.03		0.01		0.03		0.01		0.03		0.01		0.03		0.01		0.03	
Band Gap	mm			1.4			1.4			2.0			2.2			2.2			2.9			2.9				
	Inches			0.055			0.055			0.078			0.087			0.087			0.114			0.114				
Rated Voltage d.c.	50	100	200	50	100	200	50	100	200	50	100	200	50	100	200	50	100	200	50	100	200	50	100	200		
Cap. Range	Code																									
0.5pF	0R5																									
1.0	1R0																									
1.2	1R2																									
1.5	1R5																									
1.8	1R8																									
2.2	2R2																									
2.7	2R7																									
3.3	3R3																									
3.9	3R9																									
4.7	4R7																									
5.6	5R6																									
6.8	6R8																									
8.2	8R2																									
10	100																									
12	120																									
15	150																									
18	180																									
22	220																									
27	270																									
33	330																									
39	390																									
47	470																									
56	560																									
68	680																									
82	820																									
100	101																									
120	121																									
150	151																									
180	181																									
220	221																									
270	271																									
330	331																									
390	391																									
470	471																									
560	561																									
680	681																									
820	821																									
1.0nF	102																									
1.2	122																									
1.5	152																									
1.8	182																									
2.2	222																									
2.7	272																									
3.3	332																									
3.9	392																									
4.7	472																									
5.6	562																									
6.8	682																									
8.2	822																									
10	103																									
12	123																									
15	153																									
18	183																									
22	223																									
27	273																									
33	333																									
39	393																									
47	473																									
56	563																									
68	683																									
82	823																									
100	104																									
120	124																									
150	154																									
180	184																									
220	224																									
270	274																									
330	334																									
390	394																									
470	474																									
560	564																									
680	684																									
820	824																									
1.0uF	105																									
2.2	225																									
3.3	335																									
4.7	475																									
6.8	685																									
10	106																									
22	226																									



## Multilayer Ceramic Chip Capacitors X5R

	GMC21			GMC31			GMC32			GMC40			GMC43			GMC45			GMC55			GMC57		
Type	0805			1206			1210			1808			1812			1825			2220			2225		
Length	mm			3.2±0.3			3.2±0.3			4.57±0.25			4.5±0.35			4.5±0.35			5.7±0.4			5.7±0.4		
	Inches			0.125±0.012			0.125±0.012			0.18±0.01			0.18±0.014			0.18±0.014			0.225±0.016			0.225±0.016		
Width	mm			1.6±0.2			2.5±0.3			2.03±0.25			3.2±0.3			6.3±0.4			5.0±0.4			6.3±0.4		
	Inches			0.063±0.008			0.10±0.012			0.08±0.01			0.125±0.012			0.25±0.016			0.197±0.016			0.25±0.016		
Thick(Max)	mm			1.8			2.8			3.0			3.0			3.2			3.5			3.5		
	Inches			0.070			0.110			0.118			0.118			0.126			0.138			0.138		
Termination Band	Min		Max		Min		Max		Min		Max		Min		Max		Min		Max		Min		Max	
	0.25		0.75		0.25		0.75		0.25		0.75		0.25		0.75		0.25		0.75		0.25		0.75	
	0.01		0.03		0.01		0.03		0.01		0.03		0.01		0.03		0.01		0.03		0.01		0.03	
Band Gap	mm			1.4			1.4			2.0			2.2			2.2			2.9			2.9		
	Inches			0.055			0.055			0.078			0.087			0.087			0.114			0.114		
Rated Voltage d.c.	6.3	10	16	6.3	10	16	25	6.3	10	16	25	N/A	6.3	10	16	6.3	10	16	6.3	10	16	25		
Cap. Range																								
Code																								
0.5pF																								
1.0																								
1.2																								
1.5																								
1.8																								
2.2																								
2.7																								
3.3																								
3.9																								
4.7																								
5.6																								
6.8																								
8.2																								
10																								
12																								
15																								
18																								
22																								
27																								
33																								
39																								
47																								
56																								
68																								
82																								
100																								
120																								
150																								
180																								
220																								
270																								
330																								
390																								
470																								
560																								
680																								
820																								
1.0nF																								
1.2																								
1.5																								
1.8																								
2.2																								
2.7																								
3.3																								
3.9																								
4.7																								
5.6																								
6.8																								
8.2																								
10																								
12																								
15																								
18																								
22																								
27																								
33																								
39																								
47																								
56																								
68																								
82																								
100																								
120																								
150																								
180																								
220																								
270																								
330																								
390																								
470																								
560																								
680																								
820																								
1.0uF																								
2.2																								
3.3																								
4.7																								
6.8																								
10																								
22																								
33																								
47																								
100																								





## Multilayer Ceramic Chip Capacitors

### Y5V/Z5U (cont)

		GMC21		GMC31		GMC32		GMC40		GMC43		GMC45		GMC55		GMC57			
Type		0805		1206		1210		1808		1812		1825		2220		2225			
Length	mm	2.0±0.3		3.2±0.3		3.2±0.3		4.57±0.25		4.5±0.35		4.5±0.35		5.7±0.4		5.7±0.4			
	Inches	0.08±0.012		0.125±0.012		0.125±0.012		0.18±0.01		0.18±0.014		0.18±0.014		0.225±0.016		0.225±0.016			
Width	mm	1.25±0.2		1.6±0.2		2.5±0.3		2.03±0.25		3.2±0.3		6.3±0.4		5.0±0.4		6.3±0.4			
	Inches	0.05±0.008		0.063±0.008		0.10±0.012		0.08±0.01		0.125±0.012		0.25±0.016		0.197±0.016		0.25±0.016			
Thick(Max)	mm	1.5		1.8		2.8		3.0		3.0		3.2		3.5		3.5			
	Inches	0.059		0.07		0.110		0.118		0.118		0.126		0.138		0.138			
Termination Band	Min	0.25	0.25	0.25	0.25	0.25	0.25	0.25	0.25	0.25	0.25	0.25	0.25	0.25	0.25	0.25	0.25		
	Max	0.75	0.75	0.75	0.75	0.75	0.75	0.75	0.75	0.75	0.75	0.75	0.75	0.75	0.75	0.75	0.75		
	Inches	0.01	0.01	0.01	0.01	0.01	0.01	0.01	0.01	0.01	0.01	0.01	0.01	0.01	0.01	0.01	0.01		
Band Gap	mm	0.5		1.4		1.4		2.0		2.2		2.2		2.9		2.9			
	Inches	0.019		0.055		0.055		0.078		0.087		0.087		0.114		0.114			
Rated Voltage d.c.		50	100	200	50	100	200	50	100	200	50	100	200	50	100	200	50	100	200
Cap. Range	Code																		
0.5pF	0R5																		
1.0	1R0																		
1.2	1R2																		
1.5	1R5																		
1.8	1R8																		
2.2	2R2																		
2.7	2R7																		
3.3	3R3																		
3.9	3R9																		
4.7	4R7																		
5.6	5R6																		
6.8	6R8																		
8.2	8R2																		
10	100																		
12	120																		
15	150																		
18	180																		
22	220																		
27	270																		
33	330																		
39	390																		
47	470																		
56	560																		
68	680																		
82	820																		
100	101																		
120	121																		
150	151																		
180	181																		
220	221																		
270	271																		
330	331																		
390	391																		
470	471																		
560	561																		
680	681																		
820	821																		
1.0nF	102																		
1.2	122																		
1.5	152																		
1.8	182																		
2.2	222																		
2.7	272																		
3.3	332																		
3.9	392																		
4.7	472																		
5.6	562																		
6.8	682																		
8.2	822																		
10	103																		
12	123																		
15	153																		
18	183																		
22	223																		
27	273																		
33	333																		
39	393																		
47	473																		
56	563																		
68	683																		
82	823																		
100	104																		
120	124																		
150	154																		
180	184																		
220	224																		
270	274																		
330	334																		
390	394																		
470	474																		
560	564																		
680	684																		
820	824																		
1.0uF	105																		
2.2	225																		
3.3	335																		
4.7	475																		
6.8	685																		
10	106																		
22	226																		
33	336																		
47	476																		
68	686																		
100	107																		

Multilayer Ceramic Chip Capacitors



**COG Dielectric**

Ultra stable class I dielectric: linear temperature coefficient, low loss, negligible change of electrical properties with time, voltage and frequency.

Operating Temperature Range	Temperature Coefficient	Temperature Voltage Coefficient ( $\Delta C_{Max}$ @ $V_{DcW}$ )	Dissipation Factor	Insulation Resistance	Dielectric withstanding Voltage	Aging Rate	Test Parameters
-55°C to +125°C	0±30ppm/°C	0±30ppm/°C	0.1% Max, 0.02% Typical	<ul style="list-style-type: none"> <li>• 25°C, <math>V_{DcW}</math>:: &gt;100GΩF or 1000ΩF, whichever is less</li> <li>• 125°C, <math>V_{DcW}</math>:: &gt;10GΩF or 100ΩF whichever is less</li> </ul>	3 X $V_{DcW}$	0% per decade hour	<ul style="list-style-type: none"> <li>• <math>C \leq 1000pF</math> f=1MHz V=1.0Vrms ±0.2Vrms T=25°C</li> <li>• <math>C &gt; 1000pF</math> f=1KHz V=1.0Vrms ±0.2Vrms T=25°C</li> </ul>

**X7R Dielectric**

Stable class II dielectric (EIA X7R)

Operating Temperature Range	Temperature Coefficient	Temperature Voltage Coefficient ( $\Delta C_{Max}$ @ $V_{DcW}$ )	Dissipation Factor	Insulation Resistance	Dielectric withstanding Voltage	Aging Rate	Test Parameters
-55°C to +125°C	±15%	X7R Not Applicable	2.5% Max, 1.8% Typical	<ul style="list-style-type: none"> <li>• 25°C, <math>V_{DcW}</math>:: &gt;100GΩFor 1000ΩF, whichever is less</li> <li>• 125°C, <math>V_{DcW}</math>:: &gt;10GΩF or 100ΩF whichever is less</li> </ul>	2.5 X $V_{DcW}$	<2% per decade hour	1KHz, 1.0Vrms ±0.2Vrms 25°C values > or = to 10uF 1.0Vrms 120Hz

## Multilayer Ceramic Chip Capacitors - Z5U (Y5V) Dielectric



High capacitance per unit volume: general purpose product

Operating Temperature Range	Temperature Coefficient	Dissipation Factor	Insulation Resistance	Dielectric withstanding Voltage	Aging Rate	Test Parameters
-30°C to +85°C	+22% to -82%	3.0% Max, 2.0% Typical	10GΩ or 100ΩF whichever is less, 25°C, VDCW	2.5 X VDCW	3.0% per decade hour	1KHz, 1Vrms 25°C values > or = to 10uF 1.0Vrms 120Hz

### Packaging (Taping)

(Reel Type-Size)

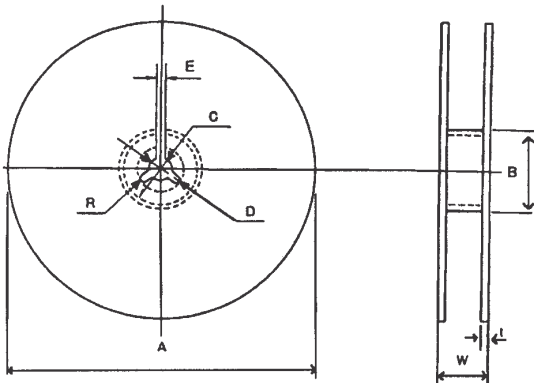

#### Standard Reel

Unit:mm

A	B	C	D	E	W	t	R
ø178 ±2.0	ø50 min.	ø13.0 ±0.5	ø21.0 ±0.8	2.0 ±0.5	14.9 ±1.5	0.8 ±0.2	1.0

#### 10000 units per reel OPTIONAL

Unit:mm

A	B	C	D	E	W	t	R
ø250 ±2.0	ø50 min.	ø13.0 ±0.5	ø21.0 ±0.8	2.0 ±0.5	10.0 ±1.5	0.8 ±0.2	1.0

#### Carrier Tape (Standard)

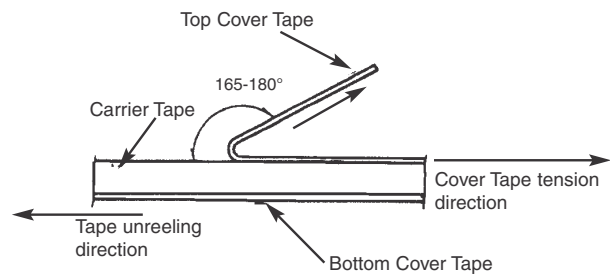

- To peel off the cover tape by the method shown in the right figure apply a peel-off force of 20 gf - 60 gf (card board); 35 gf - 75 gf (plastic tape).
- The cover tape should not touch the top or bottom of the chip.
- If the cover tape has been peeled off it may be difficult to remove the chip due to punch-hole clearance, dirt, and debris. Make sure therefore that no paper waste will adhere to and block the absorption nozzle.
- If the cover tape has been peeled off from the top, stick it back on with a suitable adhesive.
- Follow the illustration for the start and end of the winding operation.

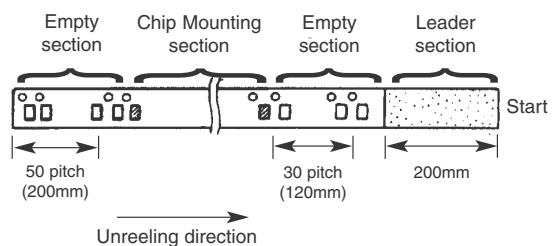

## Multilayer Ceramic Chip Capacitors

- Cardboard carrier tape for 0402, 0603 type and 0805/1206 type

Unit: mm

Type A	B W	F E	P1 P2	P0 D0	t1 t2								Mounting Hole	Quantity per Reel
0402	0.7±0.2	1.3±0.2				2.0±0.05							Angular Punch Hole	10000
0603	1.1±0.2	1.9±0.2										4000		
0805	1.65±0.2	2.4±0.2	8.0±0.3	3.5±0.05	1.75±0.1	4.0±0.1	2.0±0.05	4.0±0.1	ø1.5 <sup>+0.1</sup> <sub>-0</sub>	1.1 max	1.4 max	4000 to 5000*		
1206	2.0±0.2	3.6±0.2										4000 to 5000*		

\*Dependent on chip thickness

- Embossed plastic carrier tape for 0805/1206 type and 1210 type

Unit: mm

Type	A	B	W	F	E	P1	P2	P0	D0	t1	t2	Mounting Hole	Quantity per Reel
0805	1.45±0.2	2.3±0.2	8.0±0.3	3.5±0.05	1.75±0.1	4.0±0.1	2.0±0.05	4.0±0.1	ø1.5 <sup>+0.1</sup> <sub>-0</sub>	0.6 max	2.5 max	Angular Embossed Hole	2000 to 5000*
1206	2.0±0.2	3.6±0.2											2000 to 5000*
1210	2.9±0.2	3.6±0.2											2000 to 4000*

\*Dependent on chip thickness

- Embossed plastic carrier tape for 1812, 1825, 2220 and 2225 type

Unit: mm

Type	A	B	W	F	E	P1	P2	P0	D0	t1	t2	Mounting Hole	Quantity per Reel
1812	3.6±0.2	4.9±0.2	12.0±0.3	5.5±0.05	1.75±0.1	8.0±0.1	2.0±0.05	4.0±0.1	ø1.5±0.1	0.6 max.	6.5 max.	Angular Embossed Hole	1000
1825	6.8±0.3	4.9±0.2											1000
2220	5.5±0.3	6.2±0.3											1000
2225	6.8±0.3	6.2±0.3											1000

\*Dependent on chip thickness

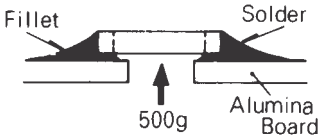
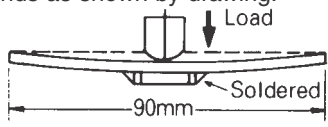

**RELIABILITY AND TEST CONDITIONS**

Item	Specification	Test Method
<b>Capacitance</b>	Within tolerance shown by part number code	<ul style="list-style-type: none"> <li>Class (I) C&lt;1000pF:1MHz±10%, 0.5 to 5Vrms C≥1000pF:1KHz±10%, 1.0±0.2Vrms</li> <li>Class (II) 1KHz±10%, 1.0±0.2Vrms values &gt; or = to 10uF 1.0Vrms 120Hz</li> </ul>
<b>Dissipation Factor (tanδ or Q)</b>	<ul style="list-style-type: none"> <li>Class (I) C&lt;30pF:Q≥400+20xC C≥30pF:Q≥1000</li> <li>Class (II) X7R:DF≤2.5% Y5V/Z5U:DF≤3.0%</li> </ul>	
<b>Insulation Resistance(IR)</b>	NPO-XR7: C≤50,000pF: IR≥100GΩ C>50,000pF: IR≥500MΩ. Per Uf. Y5V/Z5U: IR≥10GΩ	Apply rated voltage for 60 seconds at room temperature and normal humidity. (70% RH max)
<b>Dielectric Withstanding Voltage</b>	There shall be no evidence of damage or flash over during the test	Apply 3 x rated voltage (Class I) or 2.5 x rated voltage (Class II) to both terminations for 5 seconds. Charge and discharge current are less than 50mA.
<b>Termination Adherence</b>	No mechanical damage	 <p>Care shall be taken to avoid thermal shock. 500g of steady pull is applied in direction of arrow for 1 minute.</p>
<b>Bend Strength</b>	No mechanical damage	<p>After soldering capacitor on the glass-epoxy PWB, 2 mm of vending shall be applied for 10 seconds as shown by drawing.</p> 
<b>Life Test (High Temperature Loading Test)</b>	ΔC	Applied 2 x rated voltage at maximum operating temperature for 1000 hours. The surge current shall not exceed 50mA after above testing condition, test samples shall be kept in room temperature for 24 hours (Class I) or 48 hours (Class II), and then shall be measured.
	Q or DF	
	IR	



**RELIABILITY AND TEST CONDITIONS**

Item	Specification	Test Method
<b>Moisture Test</b>	<ul style="list-style-type: none"> <li>Class (I) No more than <math>\pm 5\%</math> or <math>\pm 0.5\text{pF}</math> whichever is larger</li> <li>Class (II) X7R: <math>\pm 10\%</math> Y5V/Z5U: <math>\pm 30\%</math></li> </ul>	<p>The capacitors shall be subjected to <math>40^\circ\text{C}</math>, 90-95%RH for 500 hours.</p> <p>After above testing condition, samples shall be kept in room temperature for 24 hours (Class I) or 48 hours (Class II), and then shall be measured.</p>
	<ul style="list-style-type: none"> <li>Class (I) <math>C &lt; 10\text{pF}</math>: <math>Q &gt; 200 + 10 \times C</math> <math>10 \leq C &lt; 30\text{pF}</math>: <math>Q \geq 275 + 5/2 \times C</math> <math>C \geq 30\text{pF}</math>: <math>Q \geq 350</math></li> <li>Class (II) X7R: <math>\text{DF} \leq 5.0\%</math> Y5V/Z5U: <math>\text{DF} \leq 7.5\%</math></li> </ul>	
	IR 1000M $\Omega$ or 50 $\Omega\text{F}$ , whichever is less	
<b>Moisture Resistance Test</b>	<ul style="list-style-type: none"> <li>Class (I) No more than <math>\pm 7.5\%</math> or <math>\pm 0.75\text{pF}</math> whichever is larger</li> <li>Class (II) X7R: <math>\pm 10\%</math> Y5V/Z5U: <math>\pm 30\%</math></li> </ul>	<p>Apply rated voltage at <math>40^\circ\text{C}</math>, 90-95%RH for 500 hours.</p> <p>The surge current shall not exceed 50mA. After testing with above condition, samples shall be kept in room temperature for 24 hours (Class I) or 48 hours (Class II), and then shall be measured.</p>
	<ul style="list-style-type: none"> <li>Class (I) <math>C &lt; 30\text{pF}</math>: <math>Q &gt; 100 + 100/3 \times C</math> <math>C \geq 30\text{pF}</math>: <math>Q \geq 200</math></li> <li>Class (II) X7R: <math>\text{DF} \leq 5.0\%</math> Y5V/Z5U: <math>\text{DF} \leq 7.5\%</math></li> </ul>	
	IR 500M $\Omega$ or 25 $\Omega\text{F}$ , min whichever is less	
<b>Temperature Cycle</b>	<ul style="list-style-type: none"> <li>Class (I) No more than <math>\pm 2.5\%</math> or <math>\pm 0.25\text{pF}</math> whichever is larger</li> <li>Class (II) X7R: <math>\pm 5\%</math> Y5V/Z5U: <math>\pm 20\%</math></li> </ul>	<p>Perform 5 cycles as follow:</p> <ol style="list-style-type: none"> <li>Room temperature. Dwell for 15 minutes.</li> <li>Minimum operating temperature, dwell for 30 minutes.</li> <li>Room temperature, dwell for 30 minutes.</li> <li>Maximum operating temperature, dwell for 30 minutes.</li> </ol> <p>After above testing condition, samples shall be kept in room temperature for 24 hours (Class I) or 48 hours (Class II), and then shall be measured.</p>
	Q or DF To satisfy the specified initial value.	
	IR To satisfy the specified initial value.	
<b>Solderability</b>	Termination area shall be at least 95% covered with a new solder coating. There shall be no crack and ceramic exposure of terminated surface by melting.	The capacitors are completely immersed during $4 \pm 0.5$ seconds in the molten solder with a temperature of $230 \pm 5^\circ\text{C}$ *Solder: Sn 63.
<b>Resistance to Solder Heat Test</b>	<ul style="list-style-type: none"> <li>Class (I) No more than <math>\pm 2.5\%</math> or <math>\pm 0.25\text{pF}</math> whichever is larger</li> <li>Class (II) X7R: <math>\pm 5\%</math> Y5V/Z5U: <math>\pm 20\%</math></li> </ul>	<p>Immerse into molten solder at <math>270 \pm 5^\circ\text{C}</math> for <math>3 \pm 0.5</math> seconds. Preheat before immersion.</p> <ol style="list-style-type: none"> <li><math>80 \sim 100^\circ\text{C}</math> for 2 minutes.</li> <li><math>150 \sim 180^\circ\text{C}</math> for 2 minutes.</li> <li><math>270 \pm 5^\circ\text{C}</math> for <math>3 \pm 0.5</math> seconds.</li> </ol> <p>The capacitance measurement shall be made after sample keeping at room temperature for 24 hours.</p>
	Q or DF To satisfy the specified initial value.	
	IR To satisfy the specified initial value.	



### APPLICATION MANUAL FOR SURFACE MOUNTING

#### 1. Temperature / Humidity Control

Since dew condensation may occur by the differences in temperature when the products are taken out of storage, it is important to maintain a temperature-controlled environment.

#### 2. Design of Solder Land Pattern

When designing printed circuit boards, the shape and size of the solder lands must allow for the proper amount of solder on the capacitor. The amount of solder at the end terminations has a direct effect on the probability that the chip will crack. The greater amount of solder, the larger amount of stress on the chip, and the more likely that it will break. Use the following illustrations as guidelines for proper solder land design.

Recommendation of solder land shape and size.

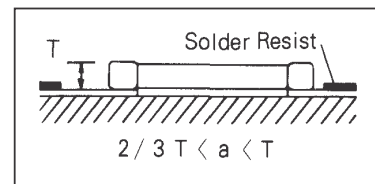
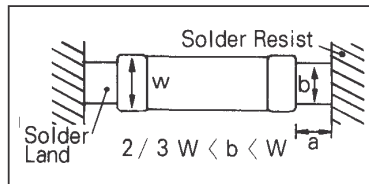

#### 3. Adhesives

MLCCs generally require the use of an adhesive to adhere the chips to the circuit board prior to wave soldering.

##### 3-1. Requirements for Adhesives

- They must have enough adhesion so that the chips will not fall off or move during the handling of the circuit board.
- They must maintain their adhesive strength when exposed to soldering temperatures.
- They should not spread or run when applied to the circuit board.
- They should have a long pot life.
- They should harden quickly.
- They should not corrode the circuit board or chip material.
- They should be a good insulator.
- They should be non-toxic, and not produce harmful gases, nor be harmful when touched.

##### 3-2. Application Method

It is important to use the proper amount of adhesive. Too little will cause poor adhesion to the circuit board, and too much may strain the conductor pattern, thereby causing defective soldering. The following illustrations show the proper quantity of adhesive.

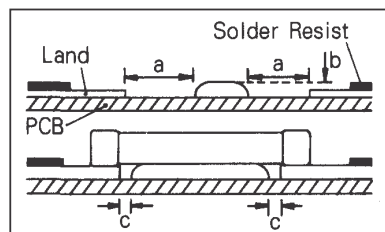

(Unit: mm)

Type	21	31
a	0.2 min	0.2 min
b	70~100μm	70~100μm
c	>0	>0

##### 3-3. Adhesive Hardening Characteristics

To prevent oxidation of the terminations, the adhesive must harden at 160°C or less, within 2 minutes or less.



#### 4. Mounting

##### 4-1. Mounting Head Pressure

Excessive pressure will cause chip capacitors to crack. The pressure between nozzle and chip capacitor will be 300g maximum during mounting.

##### 4-2. Bending Stress

Bending of printed circuit board by mounting head when double-sided circuit boards are used, chip capacitors first are mounted and soldered onto one side of the board. When the capacitors are mounted onto the other side, it is important to support the board as shown in the illustration. If the circuit board is not supported, it may bend, causing the already installed capacitors to crack.

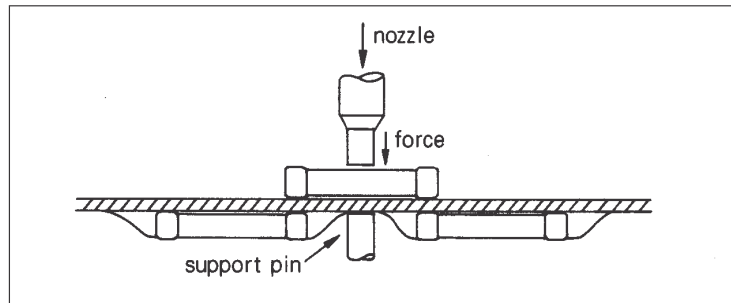

#### 5. Flux

Although highly activated flux gives better solderability, substances which increase activity may also degrade the insulation of the chip capacitors. To avoid such degradation, it is recommended that a mildly activated rosin flux (less than 0.2% chlorine) be used.

#### 6. Soldering

Since a multilayer chip ceramic capacitor comes into direct contact with melted solder during soldering, it is exposed to potentially damaging mechanical stress caused by the sudden temperature change. The capacitor may also be subject to silver migration, and to contamination by the flux. Because of these factors, soldering technique is critical.

##### 6-1. Soldering Methods

Method	Classification	
Reflow Soldering	Mass reflow	<ul style="list-style-type: none"> <li>• IR/Convection</li> <li>• VPS (Vapor phase)</li> </ul>
	Selective reflow	<ul style="list-style-type: none"> <li>• Hot air/gas</li> <li>• Laser</li> </ul>
Flow Soldering	Dual Wave	

##### 6-2. Soldering Profile

To avoid the crack problem by sudden temperature change, follow the temperature profile in the adjacent graph.

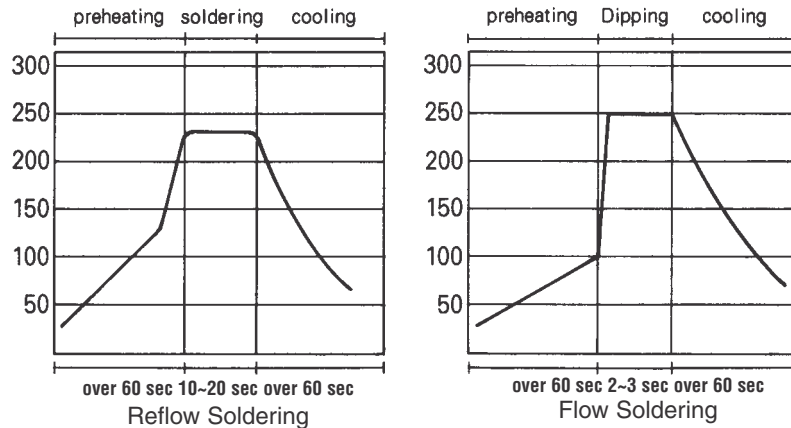

**6-3. Manual Soldering**

Manual Soldering can pose a great risk of creating thermal cracks in chip capacitors. The hot soldering iron tip comes into direct contact with the end terminations, and operator’s carelessness may cause the tip of the soldering iron to come into direct contact with the ceramic body of the capacitor. Therefore the soldering iron must be handled carefully, and close attention must be paid to the selection of the soldering iron tip and to temperature control of the tip.

**6-4. Amount of Solder**

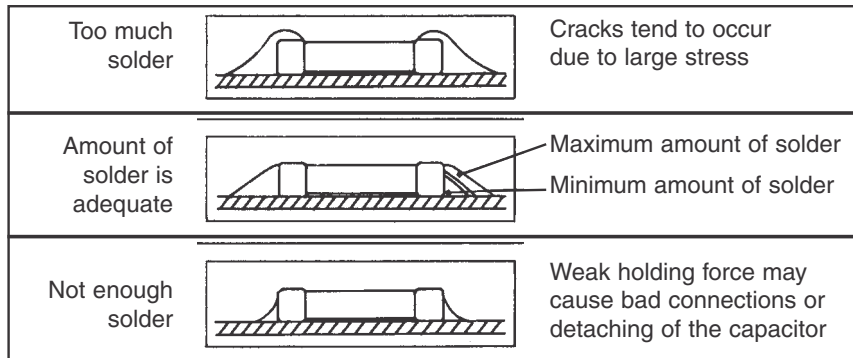

**6-5. Cooling**

Natural cooling using air is recommended. If the chips are dipped into solvent for cleaning, the temperature difference ( $\Delta T$ ) must be less than 100°C.

**6-6. Cleaning**

If rosin flux is used, cleaning usually is unnecessary. When strongly activated flux is used, chlorine in the flux may dissolve into some types of cleaning fluids, thereby affecting the chip capacitors. This means that the cleaning fluid must be carefully selected, and should always be new.

**7. Notes for Separating Multiple, Shared PC Boards**

A multi-PC board is separated into many individual circuit boards after soldering has been completed. If the board is bent or distorted at the time of separation, cracks may occur in the chip capacitors. Carefully choose a separation method that minimizes the bending of the circuit board.



### APPLICATION INFORMATION ON SOLDER PAD DESIGN FOR SURFACE MOUNT CHIP CAPACITOR

### Recommended Pad Dimensions

Chip Size	Dimensions (inches)			T
	L	W	S	
0402*	0.021	0.022	0.017	0.059
0603*	0.035	0.030	0.030	0.100
0805	0.040	0.050	0.040	0.120
1206	0.040	0.065	0.080	0.160
1210	0.040	0.100	0.080	0.160
1812*	0.050	0.120	0.130	0.230
1825*	0.050	0.250	0.130	0.230
2220	0.050	0.250	0.130	0.230
2225*	0.050	0.250	0.170	0.270
3640*	0.060	0.400	0.300	0.420

\*These sizes are recommended for use with IR and vapor phase soldering only.

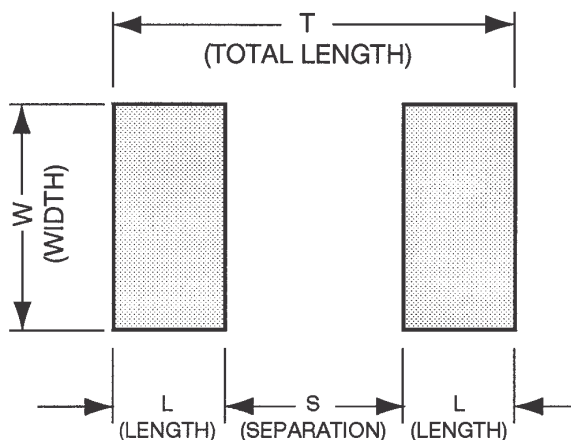

**NOTICE:** Specifications are subject to change without notice. Contact your nearest Cal-Chip Sales Office for the latest specifications. All statements, information and data given herein are believed to be accurate and reliable, but are presented without guarantee, warranty, or responsibility of any kind, expressed or implied. Statements or suggestions concerning possible use of our products are made without representation or warranty that any such use is free of patent infringement and are not recommendations to infringe any patent. The user should not assume that all safety measures are indicated or that other measures may not be required. Specifications are typical and may not apply to all applications.